

INTERNATIONAL STANDARD

IEC
61169-8

QC 222400

First edition
2007-02

Radio-frequency connectors –

Part 8:

Sectional specification –

**RF coaxial connectors with inner diameter of outer
conductor 6,5 mm (0,256 in) with bayonet lock –**

Characteristic impedance 50 Ω (type BNC)



Reference number
IEC 61169-8:2007(E)

Publication numbering

As from 1 January 1997 all IEC publications are issued with a designation in the 60000 series. For example, IEC 34-1 is now referred to as IEC 60034-1.

Consolidated editions

The IEC is now publishing consolidated versions of its publications. For example, edition numbers 1.0, 1.1 and 1.2 refer, respectively, to the base publication, the base publication incorporating amendment 1 and the base publication incorporating amendments 1 and 2.

Further information on IEC publications

The technical content of IEC publications is kept under constant review by the IEC, thus ensuring that the content reflects current technology. Information relating to this publication, including its validity, is available in the IEC Catalogue of publications (see below) in addition to new editions, amendments and corrigenda. Information on the subjects under consideration and work in progress undertaken by the technical committee which has prepared this publication, as well as the list of publications issued, is also available from the following:

- **IEC Web Site** (www.iec.ch)

- **Catalogue of IEC publications**

The on-line catalogue on the IEC web site (www.iec.ch/searchpub) enables you to search by a variety of criteria including text searches, technical committees and date of publication. On-line information is also available on recently issued publications, withdrawn and replaced publications, as well as corrigenda.

- **IEC Just Published**

This summary of recently issued publications (www.iec.ch/online_news/justpub) is also available by email. Please contact the Customer Service Centre (see below) for further information.

- **Customer Service Centre**

If you have any questions regarding this publication or need further assistance, please contact the Customer Service Centre:

Email: custserv@iec.ch
Tel: +41 22 919 02 11
Fax: +41 22 919 03 00

INTERNATIONAL STANDARD

IEC 61169-8

QC 222400

First edition
2007-02

Radio-frequency connectors –

Part 8:

Sectional specification –

**RF coaxial connectors with inner diameter of outer
conductor 6,5 mm (0,256 in) with bayonet lock –
Characteristic impedance 50 Ω (type BNC)**

© IEC 2007 — Copyright - all rights reserved

No part of this publication may be reproduced or utilized in any form or by any means, electronic or mechanical, including photocopying and microfilm, without permission in writing from the publisher.

International Electrotechnical Commission, 3, rue de Varembé, PO Box 131, CH-1211 Geneva 20, Switzerland
Telephone: +41 22 919 02 11 Telefax: +41 22 919 03 00 E-mail: inmail@iec.ch Web: www.iec.ch



Commission Electrotechnique Internationale
International Electrotechnical Commission
Международная Электротехническая Комиссия

PRICE CODE

V

For price, see current catalogue

CONTENTS

FOREWORD.....	4
1 Scope.....	6
2 Normative references	6
3 IEC type designation	6
4 Interface dimensions	7
4.1 Dimensions – General purpose connectors.....	7
5 Mechanical gauges and standard test connectors.....	11
5.1 Mechanical gauges.....	11
5.2 Standard test connectors.....	14
6 Outline dimensions.....	19
7 Quality assessment procedures.....	19
7.1 General.....	19
7.2 Ratings and characteristics	19
7.3 Test schedule and inspection requirements.....	21
7.4 Procedures.....	23
8 Instructions for preparation of detail specifications	23
8.1 General.....	23
8.2 Identification of the Detail specification	24
8.3 Identification of the component.....	24
8.4 Performance.....	24
8.5 Marking, ordering information and related matters.....	24
8.6 Selection of tests, test conditions and severities.....	24
8.7 Blank detail specification pro-forma for type BNC connector.....	26
Annex A (normative) Information for interface dimensions of 75 Ω characteristic impedance connector with unspecified reflection factor.....	31
Bibliography.....	35
Figure 1 – Connector with pin-centre contact (for dimensions, see Table 1).....	7
Figure 2 – Details of bayonet lock.....	8
Figures 3 and 4 – Details of alternative coupling grooves	8
Figure 5 – Details of pin-centre contact.....	8
Figure 6 – Connector with socket-centre contact (for dimensions, see Table 2)	10
Figure 7 – Details of socket-centre contact	10
Figure 8 – Gauge for outer contact of pin connector.....	11
Figure 9 – Gauge pin for socket-centre contact.....	12
Figure 10 – Dimensions of gauge for performance test (see Table 5).....	13
Figure 11 – Dimensions of connector (see Table 6)	15
Figure 12 – Dimensions of centre contact (see Table 6).....	15
Figure 13 – Dimensions of connector (see Table 7)	17
Figure 14 – Dimensions of centre contact (see Table 7).....	17
Figure A.1 – Connector with pin centre contact and Figure A.2 – Details of bayonet lock	31

Figure A.3 – Details of alternative coupling grooves.....	31
Figure A.4 – Details of pin centre contact	31
Figure A.5 – Connector with socket centre contact.....	33
Figure A.6 – Position of coupling studs	33
Figure A.7 – Details of socket centre contact	33
Table 1 – Dimensions for connector with pin-centre contact.....	9
Table 2 – Dimensions for connector with socket-centre contact	11
Table 3 – Dimensions for gauges for outer contact of pin connector.....	12
Table 4 – Dimensions for gauge pin for socket-centre contact.....	12
Table 5 – Dimensions of gauge for performance test	14
Table 6 – Dimensions of centre contact	16
Table 7 – Dimensions for standard test connector.....	18
Table 8 – Preferred climatic categories (see IEC 60068-1):.....	19
Table 9 – Ratings and characteristics	20
Table 10 – Acceptance tests	21
Table 11 – Periodic tests	22
Table A.1 – Dimensions for pin connector	32
Table A.2 – Dimensions for socket connector	34

INTERNATIONAL ELECTROTECHNICAL COMMISSION

RADIO-FREQUENCY CONNECTORS –**Part 8: Sectional specification – RF coaxial connectors with inner diameter of outer conductor 6,5 mm (0,256 in) with bayonet lock – Characteristic impedance 50 Ω (type BNC)**

FOREWORD

- 1) The International Electrotechnical Commission (IEC) is a worldwide organization for standardization comprising all national electrotechnical committees (IEC National Committees). The object of IEC is to promote international co-operation on all questions concerning standardization in the electrical and electronic fields. To this end and in addition to other activities, IEC publishes International Standards, Technical Specifications, Technical Reports, Publicly Available Specifications (PAS) and Guides (hereafter referred to as "IEC Publication(s)"). Their preparation is entrusted to technical committees; any IEC National Committee interested in the subject dealt with may participate in this preparatory work. International, governmental and non-governmental organizations liaising with the IEC also participate in this preparation. IEC collaborates closely with the International Organization for Standardization (ISO) in accordance with conditions determined by agreement between the two organizations.
- 2) The formal decisions or agreements of IEC on technical matters express, as nearly as possible, an international consensus of opinion on the relevant subjects since each technical committee has representation from all interested IEC National Committees.
- 3) IEC Publications have the form of recommendations for international use and are accepted by IEC National Committees in that sense. While all reasonable efforts are made to ensure that the technical content of IEC Publications is accurate, IEC cannot be held responsible for the way in which they are used or for any misinterpretation by any end user.
- 4) In order to promote international uniformity, IEC National Committees undertake to apply IEC Publications transparently to the maximum extent possible in their national and regional publications. Any divergence between any IEC Publication and the corresponding national or regional publication shall be clearly indicated in the latter.
- 5) IEC provides no marking procedure to indicate its approval and cannot be rendered responsible for any equipment declared to be in conformity with an IEC Publication.
- 6) All users should ensure that they have the latest edition of this publication.
- 7) No liability shall attach to IEC or its directors, employees, servants or agents including individual experts and members of its technical committees and IEC National Committees for any personal injury, property damage or other damage of any nature whatsoever, whether direct or indirect, or for costs (including legal fees) and expenses arising out of the publication, use of, or reliance upon, this IEC Publication or any other IEC Publications.
- 8) Attention is drawn to the Normative references cited in this publication. Use of the referenced publications is indispensable for the correct application of this publication.
- 9) Attention is drawn to the possibility that some of the elements of this IEC Publication may be the subject of patent rights. IEC shall not be held responsible for identifying any or all such patent rights.

International Standard IEC 61169-8 has been prepared by subcommittee 46F: RF and microwave passive components, of IEC technical committee 46: Cables, wires, waveguides, RF connectors, RF and microwave passive components and accessories.

This first edition of IEC 61169-8 cancels and replaces IEC 60169-8 published in 1978 as well as its Amendment 1 (1996) and Amendment 2 (1997). This edition constitutes a technical revision.

This first edition of IEC 61169-8 differs from IEC 60169-8 primarily in that it contains a new Clause 7: Quality assessment procedures and a new Clause 8: Instructions for preparation of detail specifications. Furthermore this IEC 61169-8 refers to IEC 61169-1 whereas IEC 60169-8 referred to IEC 60169-1.

The text of this standard is based on the following documents:

FDIS	Report on voting
46F/57/FDIS	46F/67/RVD

Full information on the voting for the approval of this standard can be found in the report on voting indicated in the above table.

This publication has been drafted in accordance with the ISO/IEC Directives, Part 2.

A list of all parts of the IEC 61169 series, published under the general title *Radio frequency connectors*, can be found on the IEC website.

The QC number that appears on the front cover of this publication is the specification number in the IEC Quality Assessment System for Electronic Components (IECQ).

The committee has decided that the contents of this publication will remain unchanged until the maintenance result date indicated on the IEC web site under "<http://webstore.iec.ch>" in the data related to the specific publication. At this date, the publication will be

- reconfirmed,
- withdrawn,
- replaced by a revised edition, or
- amended.

A bilingual edition of this document may be issued at a later date.

RADIO-FREQUENCY CONNECTORS –

Part 8: Sectional specification – RF coaxial connectors with inner diameter of outer conductor 6,5 mm (0,256 in) with bayonet lock – Characteristic impedance 50 Ω (type BNC)

1 Scope

This part of IEC 61169, which is a sectional specification (SS), provides information and rules for the preparation of detail specifications (DS) for RF coaxial connectors which may preferably be used with RF cables 60096 IEC 50-3 of IEC 60096-2. These connector patterns are for low power, quick connect/disconnect applications using a bayonet type coupling mechanism and are commonly known as type "BNC".

It describes the interface dimensions for general purpose connectors, dimensional details for standard test connectors together with gauging information and the mandatory tests selected from IEC 61169-1, applicable to all DS relating to type BNC connectors.

This specification indicates the recommended performance characteristics to be considered when writing a DS and covers test schedules and inspection requirements.

2 Normative references

The following referenced documents are indispensable for the application of this document. For dated references, only the edition cited applies. For undated references, the latest edition of the referenced document (including any amendments) applies.

IEC 60068-1:1988, *Environmental testing – Part 1: General and guidance*
Amendment 1 (1992)

IEC 60096-2, *Radio-frequency cables – Part 2: Relevant cable specifications*

IEC 61169-1:1992, *Radio-frequency connectors – Part 1: Generic specification – General requirements and measuring methods*

3 IEC type designation

Connectors of this standard shall be designated by:

- a) the reference to this standard, 61169-8 IEC;
- b) a serial number (see Clause 6);
- c) a letter corresponding to the climatic category (see 7.2).

Example:

61169-8-IEC-1A denotes a free pin connector belonging to climatic category 40/85/21 to be used with an RF coaxial cable 60096 IEC 50-3-1/3/4.

NOTE The type designation used in this standard is provisional. A final type designation is under consideration.

4 Interface dimensions

4.1 Dimensions – General purpose connectors

The original dimensions are in inches.

All undimensioned pictorial configurations are for reference purposes only.

4.1.1 Pin connector

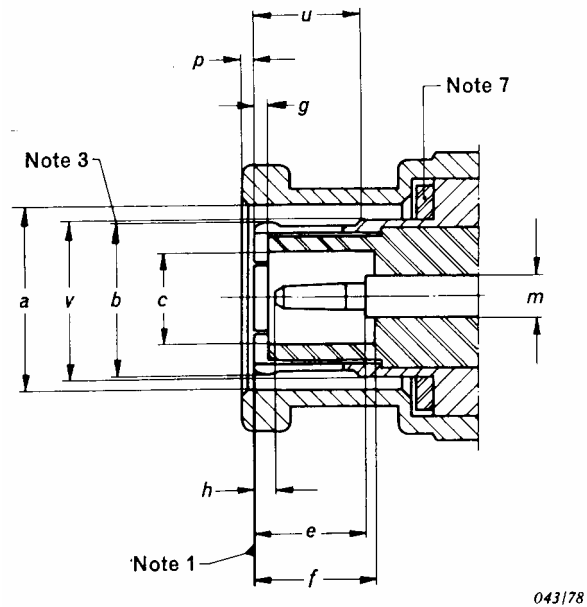

Figure 1 – Connector with pin-centre contact (for dimensions, see Table 1)

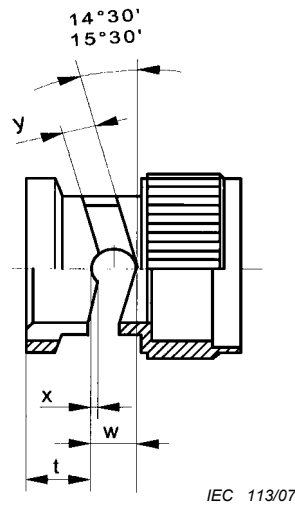
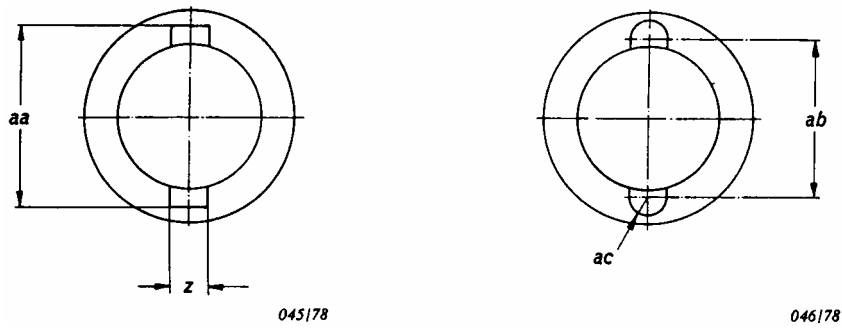

Figure 2 – Details of bayonet lock



Figures 3 and 4 – Details of alternative coupling grooves

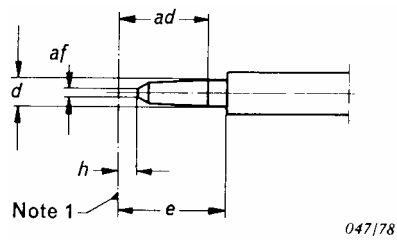

Figure 5 – Details of pin-centre contact

Table 1 – Dimensions for connector with pin-centre contact

Reference	mm		inch		Note
	Min.	Max.	Min.	Max.	
a	9,78	9,91	0,385	0,390	9/diam.
b	–	–	–	–	3/9/diam.
c	4,83	–	0,190	–	9/diam.
d	1,32	1,37	0,052	0,054	9/diam.
e	5,33	–	0,210	–	
f	5,28	–	0,208	–	
g	0,15	–	0,006	–	
h	0,08	1,02	0,003	0,040	
m	2,140 nom.		0,0842 nom.		diam.
p	1,44 nom.		0,057 nom		10
u	5,38	–	0,212	–	
v	–	8,18	–	0,322	9/diam.
z	2,31	2,46	0,091	0,097	6
aa	11,76	–	0,463	–	6
ab	10,14 nom.		0,399 nom.		6
ac	1,14	–	0,045	–	6/rad.
ad	1,96	3,05	0,077	0,120	
af	–	0,64	–	0,025	diam.
t	4,47	4,67	0,180	0,184	
w	3,15	–	0,124	–	
x	0,46	0,56	0,018	0,022	
y	2,31	2,46	0,091	0,097	
NOTE 1 Mechanical and electrical reference plane.					
NOTE 3 Slotted and flared to meet gauge test according to 5.1.1.					
NOTE 6 It is permitted to use either Figure 3 or Figure 4.					
NOTE 7 Sealing gasket to meet required electrical and environmental performance.					
NOTE 9 Diameters shall be gauged to ensure that on mmC each feature is on or can take up a common axis.					
NOTE 10 This dimension shows the position when the bayonet sleeve is locked.					

4.1.2 Socket connector

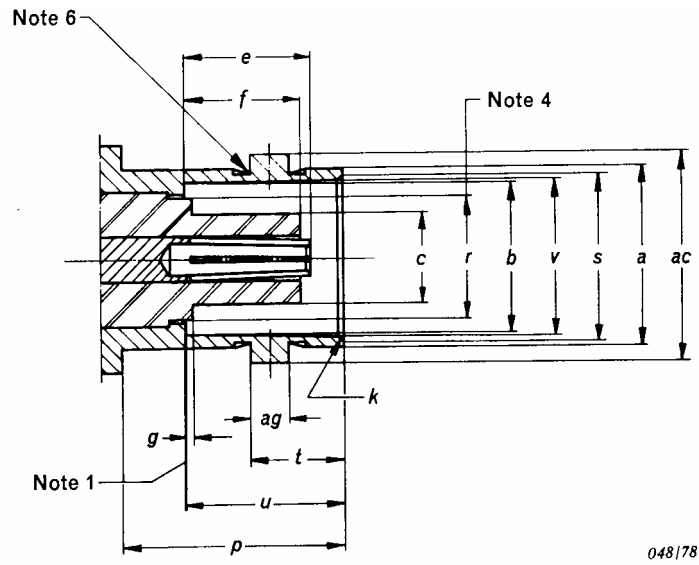

Figure 6 – Connector with socket-centre contact (for dimensions, see Table 2)

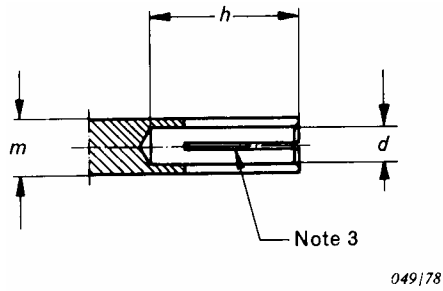

Figure 7 – Details of socket-centre contact

Table 2 – Dimensions for connector with socket-centre contact

Reference	mm		inch		Note
	Min.	Max.	Min.	Max.	
a	9,60	9,70	0,378	0,382	9/diam.
b	8,10	8,15	0,319	0,321	9/diam.
c	–	4,72	–	0,186	9/diam.
d	-	-	-	-	3/9/diam.
e	4,55	5,23	0,179	0,206	
f	-	5,28	-	0,208	
g	-	0,15	-	0,006	
h	4,95	-	0,195	-	
k	–	–	–	–	8
m	2,140 nom.		0,0842 nom.		diam.
p	10,52	-	0,414	-	
r	–	6,50	–	0,256	4/diam.
s	8,79	9,04	0,346	0,356	diam.
t	5,18	5,28	0,204	0,208	
u	8,31	8,51	0,327	0,335	
v	8,31	8,46	0,327	0,333	9/diam.
ac	10,97	11,07	0,432	0,436	9
ag	1,91	2,05	0,075	0,081	diam.

NOTE 1 Mechanical and electrical reference plane.
NOTE 3 Slotted and closed to meet requirements of 5.1.2.
NOTE 4 Applies only when dielectric extends beyond reference plane.
NOTE 6 A concave depression between studs is permissible.
NOTE 8 Chamfer or radius.
NOTE 9 Diameters shall be gauged to ensure that on mmC each feature is on or can take up a common axis.

5 Mechanical gauges and standard test connectors

5.1 Mechanical gauges

5.1.1 Connectors with pin centre contact

5.1.1.1 Gauge for outer contact of pin connector

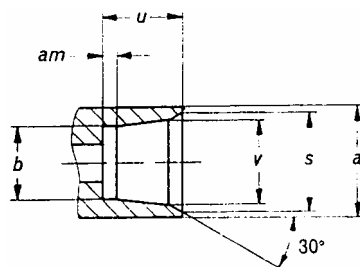

050/78

Figure 8 – Gauge for outer contact of pin connector

Table 3 – Dimensions for gauges for outer contact of pin connector

Gauge A (for sizing purposes)					Gauge B (for measurement of gauge retention force for outer conductor) Mass (weight) of gauge: 225 ± 5 g			
Reference	mm		inch		mm		inch	
	Min.	Max.	Min.	Max.	Min.	Max.	Min.	Max.
<i>a</i> φ	9,63	9,68	0,379	0,381	9,63	9,68	0,379	0,381
<i>b</i> φ	8,08	8,10	0,318	0,319	8,15	8,18	0,321	0,322
<i>u</i>	8,41	8,46	0,331	0,333	8,36	8,41	0,329	0,331
<i>v</i> φ	8,31	8,36	0,327	0,329	8,41	8,46	0,331	0,333
<i>s</i> φ	8,79 nom.		0,346 nom.		8,79 nom.		0,346 nom.	
<i>am</i>	4 nom.		0,157 nom.		4 nom.		0,157 nom.	

Material: steel, polished; surface roughness: Ra = 0,4 μm (16 μin) maximum.

5.1.1.2 Test sequence

Gauge A shall be placed over the outer electrical contact of the connector once. This is a sizing operation and should be carried out when the insulator is removed from the connector.

After this the gauge B shall be placed over the outer contact in a vertical position. The gauge shall be retained.

This test can also be carried out on connectors when the insulator is not removed.

5.1.2 Connectors with socket-centre contact

5.1.2.1 Gauge pin for socket-centre contact

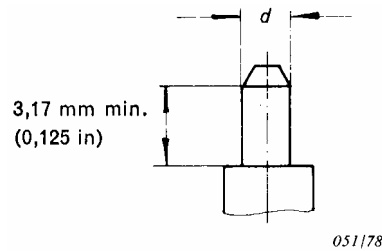

Figure 9 – Gauge pin for socket-centre contact

Table 4 – Dimensions for gauge pin for socket-centre contact

Gauge C (for sizing purposes)					Gauge D (for measurement of gauge retention force for inner conductor) Mass (weight) of gauge: 57 ± 1 g			
Reference	mm		inch		mm		inch	
	min.	max.	min.	max.	min.	max.	min.	max.
<i>d</i> φ	1,372	1,377	0,0540	0,0542	1,308	1,321	0,0515	0,0520

Material: steel, polished: surface roughness: Ra = 0,4 μm (16 μin) max.

5.1.2.2 Test sequence

A test pin gauge C shall be inserted into the centre contact a minimum distance of 3,17 mm (0,125 in) once. This is a sizing operation and should be carried out when the insulator is removed from the connector.

After this the gauge D shall be inserted in the vertical position. The gauge shall be retained.

This test can also be carried out on connectors when the insulator is not removed.

5.1.3 Gauge for outer contacts, coupling mechanism and mating face dimensions

A steel standard mating part shall be constructed as shown in Figure 10 for the connector and shall have a $0,4 \mu\text{m}$ ($16 \mu\text{in}$) maximum finish. The longitudinal force required to engage or disengage a pin connector shall not exceed 20 N.

The torque required to engage or disengage the bayonet lock of the pin connector shall not exceed 0,25 Nm.

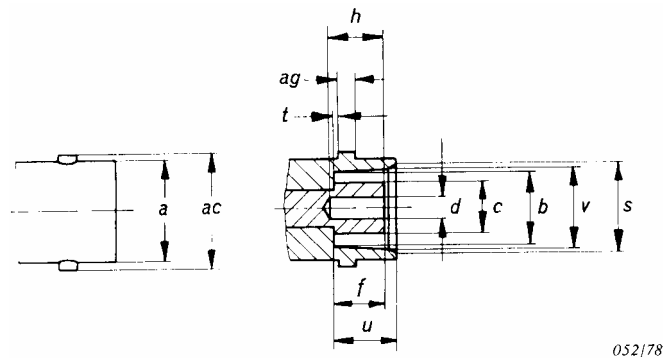

052/78

Figure 10 – Dimensions of gauge for performance test (see Table 5)

Table 5 – Dimensions of gauge for performance test

Reference	mm		inch		Note
	Min.	Max.	Min.	Max.	
<i>a</i>	9,627	9,677	0,379	0,381	diam.
<i>b</i>	8,10	8,128	0,319	0,320	diam.
<i>c</i>	4,67	4,72	0,184	0,186	diam.
<i>d</i>	1,42	–	0,056		diam.
<i>f</i>	5,21	5,28	0,205	0,208	
<i>h</i>	4,95	–	0,195	–	
<i>s</i>	8,79	8,865	0,346	0,349	diam.
<i>t</i>	2,870	3,142	0,113	0,124	
<i>u</i>	8,41	8,46	0,331	0,333	
<i>v</i>	8,30	8,382	0,327	0,330	diam.
<i>ac</i>	11,024	11,074	0,434	0,436	diam.
<i>ag</i>	1,98	2,03	0,078	0,080	

5.2 Standard test connectors

Standard test connectors are mainly used as part of the adaptor to the measuring equipment to carry out reflection coefficient measurement according to 9.2.1 of IEC 61169-1.

5.2.1 Standard test connector with pin contact

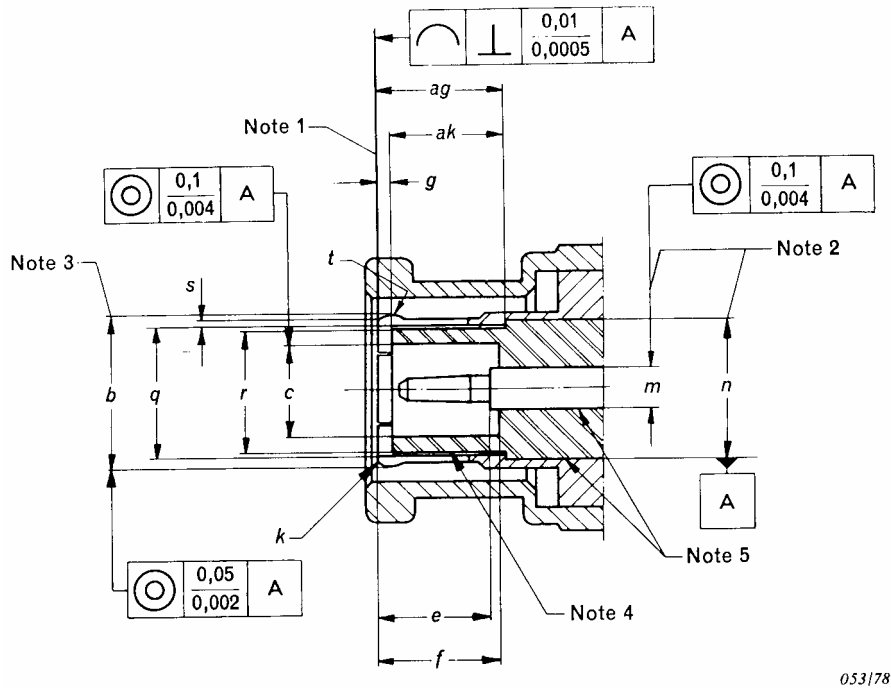

053/78

Figure 11 – Dimensions of connector (see Table 6)

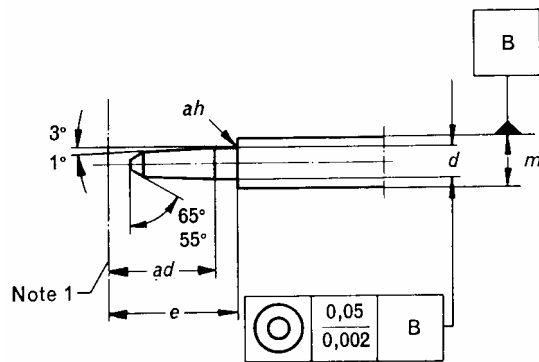

054/78

Figure 12 – Dimensions of centre contact (see Table 6)

Table 6 – Dimensions of centre contact

Reference	mm		Inch		Note
	Min.	Max.	Min.	Max.	
<i>b</i>	8,10	8,15	0,319	0,321	3/diam.
<i>c</i>	4,88	4,93	0,192	0,194	diam.
<i>d</i>	1,35	1,37	0,0530	0,0541	diam.
<i>e</i>	5,31	5,38	0,209	0,212	
<i>f</i>	5,38	5,54	0,212	0,218	
<i>g</i>	0,15	0,30	0,006	0,012	
<i>k</i>	0,13	0,20	0,005	0,008	rad.
<i>m</i>	2,13	2,15	0,0837	0,0847	2/diam.
<i>n</i>	6,99	7,01	0,2752	0,2760	2/diam.
<i>q</i>	6,72	6,74	0,2645	0,2655	diam.
<i>r</i>	6,60	6,65	0,260	0,262	diam.
<i>s</i>	0,30	–	0,012	–	plat/flat
<i>t</i>	–	0,89	–	0,035	rad.
<i>ad</i>	3,66	3,98	0,144	0,157	
<i>ag</i>	5,31	5,36	0,209	0,211	
<i>ah</i>	–	0,13	–	0,005	rad.
<i>ak</i>	5,16 nom.		0,203 nom.		

Dimensions of bayonet lock system, see 4.1.1, Figures 2, 3 and 4

NOTE 1 Mechanical and electric reference plane. Right-angled to the axis 0,01 mm (0,0005 in).

NOTE 2 These diameters are for PTFE insulation with dielectric constant 2,02. Characteristic impedance of transmission line determined by diameters “*m*” and “*n*” shall be $50 \Omega \pm 0,2 \Omega$.

NOTE 3 Dimensions before slotting:
 six slots spaced $60 \pm 1^\circ$ apart,
 0,36 mm - 0,41 mm (0,014 in - 0,016 in) wide,
 5,84 mm - 6,10 mm (0,230 in - 0,240 in) deep,
 After slotting and flaring the ID of the outer contact must be 6,718 mm to 6,744 mm (0,2645 in to 0,2655 in) when the OD of the outer contact is inserted into a ring gauge with an ID of 8,125 mm to 8,131 mm (0,3199 in to 0,3201 in).

NOTE 4 If concentric, radial air gap 0,05 mm (0,002 in) nom. When contact is inserted into a ring gauge with an ID of 8,125 mm to 8,131 mm (0,3199 in to 0,3201 in).

NOTE 5 Zero air gap.

5.2.2 Standard test connector with socket contact

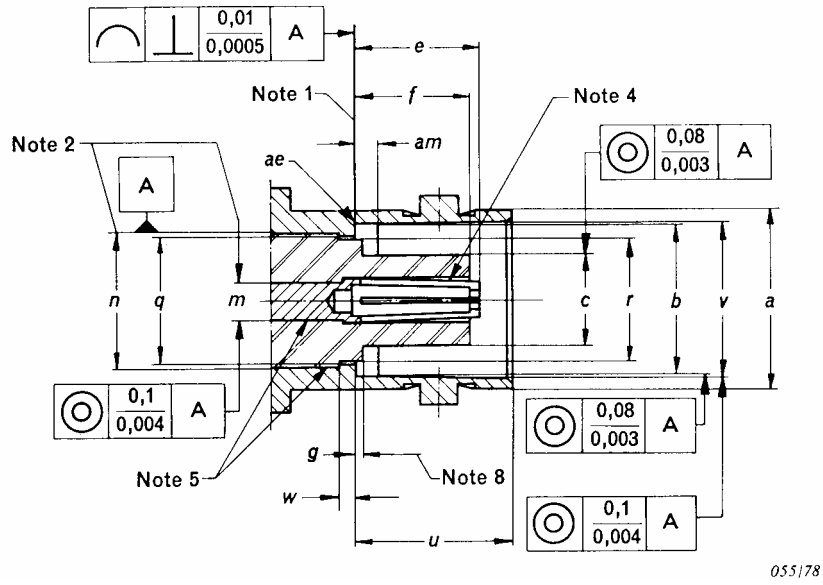

Figure 13 – Dimensions of connector (see Table 7)

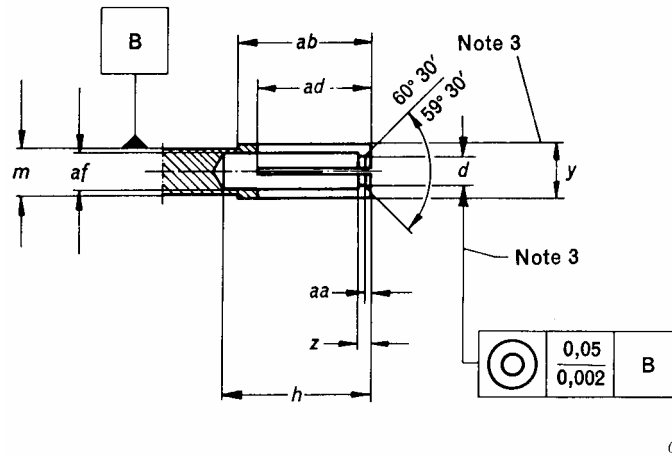

Figure 14 – Dimensions of centre contact (see Table 7)

Table 7 – Dimensions for standard test connector

Reference	mm		inch		Note
	Min.	Max.	Min.	Max.	
<i>a</i>	9,60	9,68	0,378	0,381	diam.
<i>b</i>	8,10	8,15	0,319	0,321	diam.
<i>c</i>	4,67	4,72	0,184	0,186	diam.
<i>d</i>	1,356	1,361	0,0534	0,0536	3/diam.
<i>e</i>	5,21	5,28	0,205	0,208	
<i>f</i>	5,08	5,23	0,200	0,206	
<i>g</i>	0,0	0,15	0,00	0,006	8
<i>h</i>	5,21	–	0,205	–	
<i>m</i>	2,13	2,15	0,0837	0,0847	2/diam.
<i>n</i>	6,99	7,01	0,2752	0,2760	2/diam.
<i>q</i>	6,71	6,76	0,264	0,266	diam.
<i>r</i>	6,58	6,68	0,259	0,263	diam.
<i>u</i>	8,36	8,46	0,329	0,333	
<i>v</i>	8,31	8,46	0,327	0,333	diam.
<i>w</i>	0,79	0,84	0,031	0,033	
<i>y</i>	2,16	2,18	0,0852	0,0859	3/diam.
<i>z</i>	0,38	0,89	0,015	0,035	
<i>aa</i>	0,05	0,2	0,002	0,008	
<i>ab</i>	6,05	6,10	0,238	0,240	
<i>ad</i>	4,62	4,88	0,182	0,192	
<i>ae</i>	–	0,1	–	0,004	rad.
<i>af</i>	1,52	1,63	0,060	0,064	diam.
<i>am</i>	0,51	1,02	0,020	0,040	

For dimensions not given in this table, see 4.1.2

NOTE 1 Mechanical and electric reference plane.

NOTE 2 These diameters are for PTFE insulation with dielectric constant 2,02. Characteristic impedance of transmission line determined by diameters “*m*” and “*n*” shall be $50 \Omega \pm 0,2 \Omega$.

NOTE 3 Four slots 0,18 mm - 0,23 mm (0,007in - 0,009 in) wide; between 90° 30' and 80° 30' apart; diameter “*y*” with 1,356 mm (0,0534 in) min.; 1,361 mm (0,0536 in) max.; pin gauge inserted after slotting and closing.

NOTE 4 If concentric 0,02 mm (0,0008 in) radial air gap when mated with 1,359 mm (0,0535 in) diameter pin.

NOTE 5 Zero air gap.

NOTE 8 Insulator shall be flush or protruding.

6 Outline dimensions

Under consideration.

7 Quality assessment procedures

7.1 General

The following subclauses provide recommended ratings, performance and test conditions to be considered when writing a detail specification (DS). They also provide an appropriate schedule of tests with minimum levels of conformance inspection.

7.2 Ratings and characteristics

This standard specified pin and socket connectors with bayonet lock with a nominal inner diameter of the outer conductor of 6,5 mm (0,256 in). Cable mounting connectors will function within specification requirements with 3 mm cables up to a frequency of at least 3 GHz, and may be used at higher frequencies if a reflection coefficient greater than 0,1 can be tolerated for straight connectors and 0,13 for right angle styles.

The connectors have a maximum working voltage of 500 V at sea level (125 V at 44 mbar/ 20 000 m altitude). Connection to the cable may be made either by crimping or soldering, depending upon design.

NOTE 1 Patterns for crimping are under consideration. Certain connectors have both barrier and panel seals.

NOTE 2 All voltages specified in this standard are r.m.s. values of a.c. voltages. All test voltages are a.c. voltages of 50 Hz to 60 Hz.

NOTE 3 For details of symbols, abbreviations and procedures, see 7.3.2.

Table 8 – Preferred climatic categories (see IEC 60068-1)

Category	Designation letter*	Temperature range	Damp heat, steady state
40/85/21	A	–40 °C to +85 °C	21 days
40/155/21	B	–40 °C to +155 °C	21 days
55/155/56	C	–55 °C to +155 °C	56 days

* To be included in the IEC type designation (see Clause 3).

Table 9 – Ratings and characteristics

Ratings and characteristics	IEC 61169-1 subclause	Value	Remarks including any deviations from standard test methods
<i>Electrical</i>			
Nominal impedance		50 Ω	
Frequency range – Grade 2 connectors		Up to 4 GHz	
Reflection factor – straight styles ^a – right angle styles – component mounting styles – solder bucket and PCB mounting styles	9.2.1	≤ 0,13 ≤ 0,15 As specified in the DS As specified in the DS	
Centre contact resistance – initial – after conditioning	9.2.3	≤ 1,5 mΩ ≤ 2,5 mΩ	
Outer conductor continuity ^a – initial – after conditioning	9.2.3	≤ 1 mΩ ≤ 2 mΩ	
Insulation resistance ^a – initial – after conditioning	9.2.5	≥ 5 GΩ ≥ 200 MΩ	
Proof voltage at sea level ^{b c} – cables 60096 IEC 50-4 – cables 60096 IEC 50-3 – cables 60096 IEC 50-2	9.2.6	1500 V 1000 V 750 V	
Proof voltage at 4,4 kPa ^{b c} – cables 60096 IEC 50-4 – cables 60096 IEC 50-3 – cables 60096 IEC 50-2	9.2.6	180 V 180 V 150 V	4,4 kPa approximately equivalent to 20 km
Screening effectiveness (straight cabled connectors only)	9.2.8	55 dB to 3 GHz	$Z_t \leq 178 \text{ m}\Omega$
Discharge test (Corona) – at sea level (cable 60096 IEC 50-3)	9.2.9	≥ 500 V	Extinction voltage
<i>Mechanical</i>			
Centre contact captivation – axial force – torque	9.3.5	15 N na	Maximum displacement 0,25 mm each direction
Engagement and separation force and torque, bayonet coupling – axial force – torque	9.3.6	≤ 20 N 0 to 0,25 Nm.	
Gauge retention force (resilient contacts) – centre – outer	9.3.4	0,57 N 2,25 N	
Mechanical tests on cable fixing cable pulling, force minimum – cables 60096 IEC 50-4 – cables 60096 IEC 50-3 – cables 60096 IEC 50-2	9.3.7	300 N 180 N 100 N	
Cable torsion – cables 60096 IEC 50-4 – cables 60096 IEC 50-3 – cables 60096 IEC 50-2	9.3.10	0,40 Nm 0,30 Nm 0,15 Nm	
Tensile strength of coupling mechanism	9.3.11	445 N	
Bending moment (and sharing force)	9.3.12	1 Nm	Relative to reference plane

Ratings and characteristics	IEC 61169-1 subclause	Value	Remarks including any deviations from standard test methods
Vibration	9.3.3	100 m/s ² 10 Hz – 2 000 Hz	10 g _n acceleration
Bump	9.3.13	–	
Shock	9.3.14	500 m/s ² ½ sin 6 ms	50 g _n acceleration
<i>Environmental</i>			
Climatic category ^d		40/155/21	
Sealing – non-hermetic	9.4.5.1	1 cm ³ /h max. 100 kPa – 110 kPa differential	
Sealing – hermetic	9.4.5.2	1 Pa cm ³ /s (10 ⁻⁵ bar cm ³ /s) 100 kPa – 110 kPa differential	
Salt mist	9.4.6	Duration of spraying: 48 h	
<i>Endurance</i>			
Mechanical	9.5	500 operations	
High temperature ^d	9.6	1 000 h at 155 °C	
<p>^a These values apply to basic connectors. They depend on the cable used. Relevant values are given in the DS.</p> <p>^b Voltage values are r.m.s. values at 50-60 Hz, unless otherwise specified.</p> <p>^c Cables used with these connectors may have values of lower performance than those given in this table.</p> <p>^d For certain connectors the upper temperature limit is restricted by the cable characteristics. Reference should be made to the relevant cable specification.</p>			

7.3 Test schedule and inspection requirements

7.3.1 Acceptance tests

Table 10 – Acceptance tests

	Test method IEC 61169-1 subclause	Assessment level M (higher)				Assessment level H (lower)			
		Test Required	IL	AQL %	Period	Test Required	IL	AQL %	Period
<i>Group A1</i>									
Visual examination	9.1.2	a	II	1,0		a	S3	1,5	
<i>Group B1</i>									
Outline dimensions	9.1.3.1	a	S4	0,4		a	S3	4,0	
Mechanical compatibility	9.1.3.3	a	II	1,0		a	S3	1,5	
Engagement and separation	9.3.6	a	S4	0,40	Lot	a	S3	1,5	Lot
Gauge retention (resilient contact)	9.3.4	ia	II	1,0		ia	S3	1,5	
Sealing, non-hermetic	9.4.5.1	ia	II	0,65	by	ia	S3	1,0	by
Sealing, hermetic	9.4.5.2	ia	II	0,015		ia	S3	0,025	
Voltage proof	9.2.6	a	S4	0,40	lot	a	II	4,0	lot
Solderability piece parts	9.3.2.1.1	ia	S4	0,40		ia	S3	4,0	
Insulation resistance	9.2.5	a	S4	0,40		a	S3	4,0	

7.3.2 Periodic tests

There are no group C tests for levels H and M.

NOTE For details of symbols, abbreviations and procedures, see Table 11.

Table 11 – Periodic tests

	Test method IEC 61169-1 subclause	Assessment level M (higher)				Assessment level H (lower)			
		Test required	Number of specimens	Permitted failures per group#	Period	Test required	Number of specimens	Permitted failures per group#	Period
<i>Group D1 (d)</i>			6	1	3 years		3	1	3 years
Solderability connector assemblies	9.3.2.1.1	ia				ia			
Resistance to soldering heat	9.3.2.1.2	ia				ia			
Mechanical tests on cable fixing									
– cable rotation (nutation)	9.3.7.2	ia				ia			
– cable pulling	9.3.8	ia				ia			
– cable bending	9.3.9	ia				ia			
– cable torsion	9.3.10	ia				ia			
<i>Group D2 (d)</i>			6	1	3 years		3	1	3 years
Contact resistance, outer conductor and screen continuity centre conductor continuity	9.2.3	a				a			
Vibration	9.3.3	a							
Damp heat, steady state	9.4.3	a				a			
<i>Group D3 (d)</i>			1*	1	3 years		1*	1	3 years
Dimensions piece-parts and materials	9.1.3.2	a				a			
<i>Group D4 (d)</i>			6	1	3 years		3	1	3 years
Mechanical endurance	9.5	a				a			
High temperature endurance	9.6	a				a			
Sulphur dioxide	9.4.8	na				na			
<i>Group D5 (d)</i>			6	1	3 years		3	1	3 years
Reflection factor	9.2.1	a				a			
Screening effectiveness	9.2.8	a				a			
Water immersion	9.2.7	ia				ia			

	Test method IEC 61169-1 subclause	Assessment level M (higher)				Assessment level H (lower)			
		Test required	Number of specimens	Permitted failures per group#	Period	Test required	Number of specimens	Permitted failures per group#	Period
<i>Group D6 (d)</i>			6	1	3 years		3	1	3 years
Contact captivity	9.3.5	a				a			
Rapid change of temperature	9.4.4	na				na			
Climatic sequence	9.4.2	a				a			
<i>Group D7 (d)</i>			1§		3 years		1§		3 years
Resistance to solvents and contaminating fluids	9.7	ia				ia			
<i>Details of symbols, abbreviations and procedures:</i>									
a = suggested as applicable									
ia = test suggested (if technically applicable)									
na = not applicable									
IL = Inspection Level									
AQL = Acceptable Quality Level									
* = one set of piece-parts each style and variant, unless using common piece parts									
# = for Qualification Approval (QA) a total of two failures only permitted for level H and 1 failure only for level M from groups D1 to D7									
§ = Group D7 – number of pairs for each solvent									
(d) = destructive tests – specimens shall not be returned to stock									

7.4 Procedures

7.4.1 Quality conformance inspection

This shall consist of test groups A1 and B1 on a lot-by-lot basis.

7.4.2 Qualification approval and its maintenance

This shall consist of three consecutive lots passing test groups A1 and B1 followed by selection of specimens from the lots as appropriate. These specimens shall successfully pass the specified periodic D tests.

8 Instructions for preparation of detail specifications

8.1 General

Detail specifications (DS) writers shall use the appropriate BDS pro-forma. The following pages comprise the pro-forma BDS dedicated for use with type BNC connectors. As such, it will already have entered on it information relating to

- a) the basic specification number applicable to all the detail specifications covering connector styles of the type covered by the sectional specification;
- b) the connector series designation.

The specification writer should enter the details relating to the connector style/variant(s) to be covered as indicated. The numbers in brackets on the BDS pro-forma correspond to the following indications which shall be given.

8.2 Identification of the Detail specification

- (1) The name of the National Standards Organization (NSO) under whose authority the DS is published and, if applicable, the organization from whom the DS is available.
- (2) The relevant mark of conformity and the number allotted to the DS by the relevant national or international organization authorizing the DS
- (3) The number and issue number of the IEC/IECQ generic or sectional specification as relevant; also national reference if different.
- (4) If different from the IEC/IECQ number, any national number of the DS, date of issue and any further information required by the national system, together with any amendment numbers.

8.3 Identification of the component

- (5) Enter the following details:

Style: The style designation of the connector including type of fixing and sealing, if applicable.

Attachment: By deletion of the inapplicable options of cable/wire: given for centre and outer conductors.

Special features and markings: As applicable.

- (6) Enter details of assessment level and the climatic category.
- (7) A reproduction of the outline drawing and details of the panel piercing, if applicable. It shall provide the maximum envelope dimensions, also the position of the reference plane and, in the case of a fixed connector, the position of the mounting plane(s) relative to the front face of the connector.

Any maximum panel thickness limitations for fixed connectors shall be stated.

- (8) Particulars of all variants covered by the DS. As appropriate, the information shall include:
 - cable types (or sizes) applicable to each variant;
 - alternative plated or protective finishes;
 - details of alternative mounting flanges having either tapped or plain mounting holes;
 - details of alternative solder spills or solder buckets including, when applicable, those for use with Microwave Integrated Circuit (MIC) components.

8.4 Performance

- (9) Performance data listing the most important characteristics of the connector taking into account the recommended values of 7.2 in this specification. Deviations from the minimum requirements shall be clearly indicated. Non-applicable parameters shall be marked 'na'.

8.5 Marking, ordering information and related matters

- (10) Insert marking and ordering information as appropriate, together with details of related documents and any invoked structural similarity.

8.6 Selection of tests, test conditions and severities

- (11) 'na' shall be used to indicate non-applicable tests. All tests marked 'a' by the detail specification writer shall be mandatory.

When using the normal procedure with a dedicated BDS, the letter 'a' – for applicable – shall be entered in the 'Test required' column against each of the tests indicated as being mandatory in the test schedule as in 7.3 of this specification. Any additional tests required at the discretion of the specification writer shall also be indicated by an 'a'.

The specification writer shall also indicate, when necessary, details of deviations from the standard test methods and test conditions, including any relevant deviations given in the test schedule of the sectional specification.

The qualification approval and conformance inspection shall be such that the National Supervising Inspectorate (NSI) shall be satisfied that they are appropriate and in line with those for other connectors within the system providing a reasonably comparable service.

(9) Performance (including limiting conditions of use)

Ratings and characteristics	IEC 61169-1 (QC 22000) subclause	Value	Remarks including any deviations from standard test methods
<i>Electrical</i>			
Nominal impedance	Ω	
Frequency range	GHz	Measurement frequency range
Reflection factor	9.2.1		
Variant No. Designation			
01.....	
.....	
Centre contact resistance	9.2.3	≤mΩ ≤mΩ	Initial After conditioning
Centre conductor continuity	9.2.3mΩmΩmΩmΩ	Resistance change due to conditioning
01.....			
.....			
.....			
.....			
Outer contact continuity	9.2.3	≤mΩ ≤mΩ	Initial After conditioning
Insulation resistance	9.2.5	≥GΩ ≥GΩ	Initial After conditioning
+ Proof voltage at sea level	9.2.6kVkVkVkV	86 kPa - 106 kPa
01.....			
.....			
.....			
.....			
+ Proof voltage at 4,4 kPa	9.2.6VVVVkPa (if not 4,4 kPa)
01.....			
.....			
.....			
.....			
Screening effectiveness	9.2.8dB at....GHz	Z _t ≤ mΩ
01.....			
.....			
.....			
.....			
Discharge test (corona) at sea level	9.2.9	≥ V ≥ V ≥ V ≥ V	Extinction voltage
01.....			
.....			
.....			
.....			
ADDITIONAL ELECTRICAL CHARACTERISTICS			
+ Voltage values are r.m.s. values at 50 Hz - 60 Hz, unless otherwise specified.			

Ratings and characteristics	IEC 61169-1 (QC 220000) subclause	Value	Remarks including any deviations from standard test methods
<i>Mechanical</i>			
Soldering - bit size	9.3.2.1.1	
Gauge retention resilient contacts - inner contact - outer contact	9.3.4.3NN	
Centre contact captivation - axial force - permitted displacement each direction - torque	9.3.5NmmNm	
Engagement and separation - axial force	9.3.6		
Strength of coupling mechanism	9.3.11N	
Effectiveness of cable fixing against			
- cable rotation 01.....	9.3.7	Rotations	
- cable pulling 01.....	9.3.8N	
- cable bending 01.....	9.3.9Cycles	Length of cable mass
- cable torsion 01.....	9.3.10Nm	
Bending moment	9.3.12Nm	Relative to reference plane
Bumps total	9.3.13m/s ²to..... Hz	(.....g _n acceleration)
Vibration	9.3.3m/s ²to..... Hz	(.....g _n acceleration)
Shock	9.3.14m/s ²Shapems	(.....g _n acceleration)
ADDITIONAL MECHANICAL CHARACTERISTICS			

Ratings and characteristics	IEC 61169-1 (QC 220000) Subclause	Value	Remarks including any deviations from standard test methods
<i>Environmental</i> Climatic category Sealing non-hermetically sealed connectors Sealing hermetically sealed connectors Water immersion Salt mist ADDITIONAL ENVIRONMENTAL CHARACTERISTICS	 9.4.5.1 9.4.5.2 9.2.7 9.4.6	/...../.....cm ³ /h 10 ⁻⁵ bar/cm ³ /h h	 100 kPa to 110 kPa pressure differential 100 kPa to 110 kPa pressure differential Duration of spraying
<i>ENDURANCE</i> Mechanical High temperature ADDITIONAL ENDURANCE CHARACTERISTICS	 9.5 9.6	operationsh at.....°C	
<i>CHEMICAL CONTAMINATION</i> Resistance to solvents and contaminating fluids to be used. Applicable fluids. Sulphur dioxide	 9.7 9.4.8	 days	

(10) Supplementary information

- Marking of the component: in accordance with 11.1 of IEC 61169-1 (QC 220000) in the following order of preference:
 - 1) Manufacturer code:
 - 2) Manufacturing date code: year/week
 - 3) Component identification: Variant No. / Identification
Designation
.....
.....
.....
.....
.....
.....
.....
.....
.....

- Marking and contents of package: in accordance with 11.2 of IEC 61169-1
 - 1) Information prescribed in 11.1 of IEC 61169-1 detailed above
 - 2) Nominal characteristic impedance Ω.....
 - 3) Assessment level code letter
 - 4) Any additional marking required

- Ordering information
 - 1) Number of the detail specification IECQC 222XXX...../Variant code
 - 2) Assessment level code letter
 - 3) Body finish (if more than one listed)
 - 4) Any additional information or special requirements

- Related documents (if not included in IEC 61169-1 or sectional specification):
.....
.....

- Structural similarity in accordance with 10.2.2 of IEC 61169-1
NOTE Relevant information on a basic style should be entered as variant 01.

Annex A
(normative)

Information for interface dimensions of 75 Ω characteristic impedance connector with unspecified reflection factor

A.1 Dimensions – General purpose connectors

The following interface dimensions for 75 Ω BNC connectors ensure that these connectors will mate with the 50 Ω BNC connectors described in the standard in a non-destructive manner. Inch dimensions are original dimensions.

A.2 Pin connector (for dimensions see Table A.1)

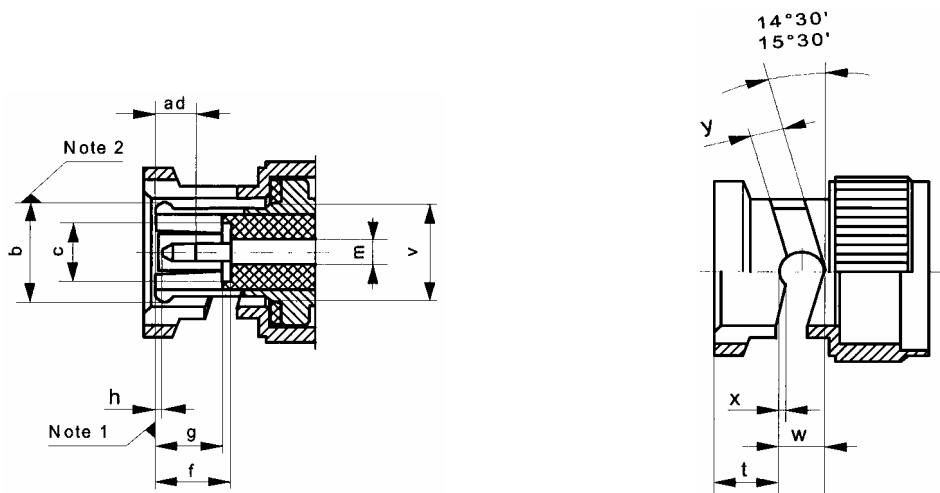

Figure A.1 – Connector with pin centre contact Figure A.2 – Details of bayonet lock

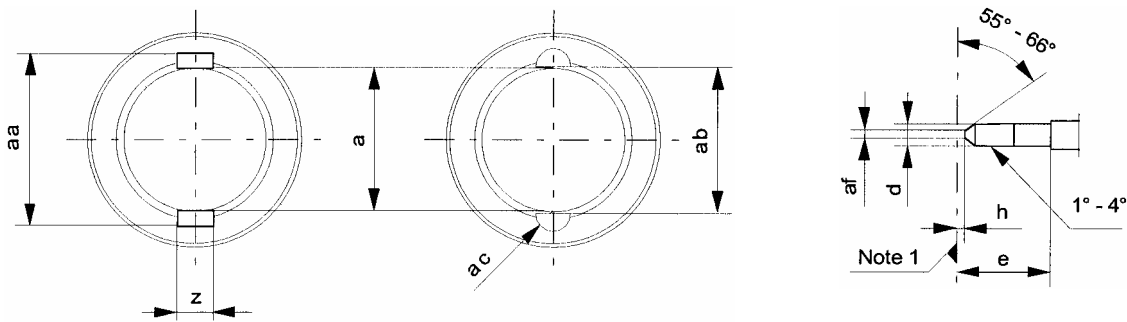

Figure A.3a

Figure A.3b

Figure A.3 – Details of alternative coupling grooves

Figure A.4 – Details of pin centre contact

Table A.1 – Dimensions for pin connector

Ref.	Mm		in		Notes
	Min.	Max.	Min.	Max.	
a	9,78	9,91	0,385	0,390	6/diam
b	–	–	–	–	2/6diam.
c	4,83	–	0,190	–	3/6/diam
d	1,32	1,37	0,052	0,054	3/diam.
e	5,33	–	0,210	–	
f	5,28	5,79	0,208	0,228	4
g	4,30	5,30	0,169	0,209	3
h	0,08	1,02	0,003	0,040	
m	2,06	2,21	0,081	0,087	diam
t	4,47	4,67	0,180	0,184	
v	–	8,18	–	0,322	6/diam
w	3,15	–	0,124	–	
x	0,46	0,56	0,018	0,022	
y	2,31	2,46	0,091	0,097	
z	2,31	2,46	0,091	0,097	5
aa	11,76	12,01	0,463	0,473	5
ab	10,01	10,16	0,394	0,400	5
ac	1,14	1,24	0,045	0,049	5/rad
ad	–	3,86	–	0,152	
af	–	0,64	–	0,025	diam.

NOTE 1 Mechanical and electrical reference plane.
 NOTE 2 Slotted and flared to meet electrical and mechanical requirements.
 NOTE 3 Reference c and reference g are applicable only when the dielectric support is counterbored.
 NOTE 4 Reference f also specifies the end of the dielectric support that is not counterbored.
 NOTE 5 It is permitted to use either Figure A.3a or Figure A.3b.
 NOTE 6 Diameters on mmC shall be on or be capable of taking a common axis.

A.3 Socket connector (for dimensions see Table A.2)

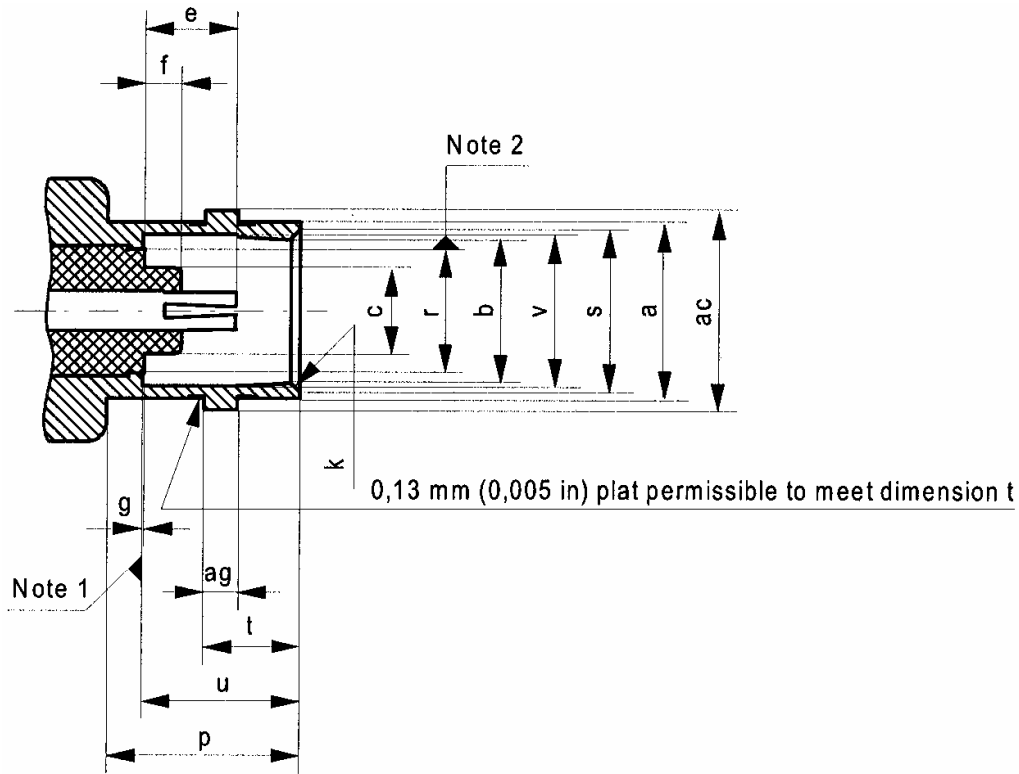

Figure A.5 – Connector with socket centre contact

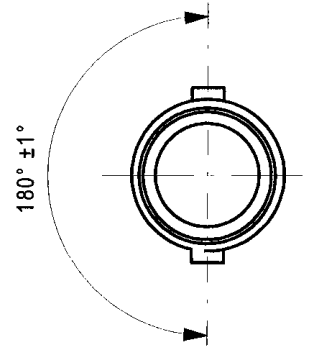

Figure A.6 – Position of coupling studs

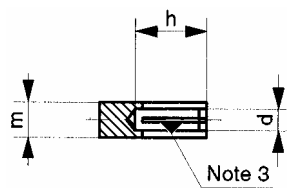

Figure A.7 – Details of socket centre contact

Table A.2 – Dimensions for socket connector

Ref.	Mm		in		Notes
	Min.	Max.	Min.	Max.	
a	9,60	9,70	0,378	0,382	5/diam
b	8,10	8,15	0,319	0,321	5/diam
c	–	4,72	–	0,186	5/diam
d	–	–	–	–	3/5/diam
e	4,72	5,23	0,186	0,206	
f	–	2,31	–	0,091	
g	–	0,15	–	0,006	8
h	4,95	–	0,195	–	
k	–	–	–	–	4
m	1,88	2,29	0,074	0,090	diam
p	10,52	–	0,414	–	
r	–	6,50	–	0,256	2/diam
s	8,79	9,04	0,346	0,356	diam
t	5,18	5,28	0,204	0,208	
u	8,31	8,51	0,327	0,335	
v	8,31	8,46	0,327	0,333	5/diam
ac	10,97	11,07	0,432	0,436	5
ag	1,91	2,06	0,075	0,081	diam

NOTE 1 Mechanical and electrical reference plane.
 NOTE 2 Applies only when dielectric extends beyond reference plane.
 NOTE 3 Slotted and closed to meet electrical and mechanical requirements.
 NOTE 4 Chamfer or radius.
 NOTE 5 Diameters on mmC shall be on or capable of taking up common axis.

Bibliography

IEC 60068-2-1:1990, *Environmental testing – Part 2: Test – Tests A: Cold*

IEC 60068-2-2:1974, *Basic environmental testing procedures – Part 2: Tests – Test B: Dry heat*

IEC 60068-2-11:1981, *Basic environmental testing procedures – Part 2: Tests – Test Ka: Salt mist*

IEC 60068-2-13:1983, *Basic environmental testing procedures – Part 2: Tests – Test M: Low air pressure*

IEC 60068-2-14:1984, *Basic environmental testing procedures – Part 2: Tests – Test N: Change of temperature*
Amendment 1 (1986)

IEC 60068-2-20:1979, *Basic environmental testing procedures – Part 2: Test – Test T: Soldering*

IEC 60068-2-30:2005, *Environmental testing – Part 2-30: Tests. Test Db: Damp heat, cyclic (12 h + 12 h cycle)*

IEC 60068-2-78:2001, *Environmental testing – Part 2-78: Tests - Test Cab: Damp heat, steady state*

ISBN 2-8318-8994-4



9 782831 889948

ICS 29.120.20
